

**TEST REPORT No. 217-3 SF/23 U**

page (pages)

**Date: 23 of November 2023**

1 (6)

**Determination of thermal resistance of reflective insulation product according  
LST EN ISO 22097:2023 and LST EN ISO 8990:1999**

(test title)

**Test method:** LST EN ISO 22097:2023 Thermal insulation for buildings-Reflective insulation products-  
Determination of thermal performance (ISO 22097:2023);  
LST EN ISO 8990:1999 Thermal insulation - Determination of steady-state thermal  
transmission properties - Calibrated and guarded hot box (ISO 8990:1994).

(number of normative document or test method, description of test procedure, test uncertainty)

**Specimen description:** **Product:** reflective multilayer insulation product Type 3  
**Name of product: BOLTHERM 820**

Thickness of product installed in the „Hot box” – 20 mm

Declared thickness of product – 20 mm \*

\* Declaration number: ETA 22/0178

(name, description and identification details of a specimen)

**Customer:** Parque Industrial, Rua M, Lote 15, 6200-027, Covilha, Portugal

(name and address)

**Manufacturer:** Parque Industrial, Rua M, Lote 15, 6200-027, Covilha, Portugal

(name and address)

**Test results:**

Name of the indicator and unit	Test method reference no.	Test result
Thermal resistance $R$ with 2 air gaps, (m <sup>2</sup> ·K)/W	LST EN ISO 8990:1999 LST EN ISO 22097:2023	1.32
$R$ -core thermal resistance of product <b>BOLTHERM 820</b> , (m <sup>2</sup> ·K)/W	LST EN ISO 22097:2023	0.70 *

Position of specimen: vertical (direction of heat flow – horizontal)  
\*  $R$ -core value of direct measurement in “Hot box”

**Tested at:** Building Physics Laboratory, Institute of Architecture and Construction of Kaunas  
University of Technology

(name of the test laboratory)

**Specimen delivery date:** 2023-10-12 **Date of testing:** 2023-11-21 **Production data:** 2023-10-31

**Sampling:** The test specimen sampled by customer.

**Additional information:** Application – 2023-09-01;  
Description of the sample – 2023-09-01

(any deviations, complementary tests, exceptions and any information related with particular test)

**Annexes:** *Annex 1.* Test results;  
*Annex 2.* Parameters of Guarded Hot Box measurement;  
*Annex 3.* Specimen products and air gaps thermal properties;  
*Annex 4.* Perimeter zone’s linear thermal transmittance value of the specimen;  
*Annex 5.* Specimen design data;  
*Annex 6.* Scheme of climate chamber „Hot box”.

(indicate annex numbers and titles)

**Head of Laboratory:**

(approves the test results)

(signature)

K. Banionis

(n., surname)

**Tested by:**

(technically responsible for testing)

(signature)

A. Burlingis

(n., surname)

Validity – the named data and results refer exclusively to the tested and described specimens.  
Notes on publication – no part of this document may be photocopied, reproduced or translated to another language without the  
prior written consent of the Building Physics Laboratory.

Annex 1. Test results:

Data element	unit	Value
Air velocity on warm side, downwards, $v_i$	m/s	0.11
Air velocity on cold side, upwards, $v_e$	m/s	4.54
Total power input to metering box, $\Phi_{in}$	W	44.057
Heat flow density through a specimen, $q_{sp}$	W/m <sup>2</sup>	14.3033
Corrected heat flow density through a specimen, $q_c$	W/m <sup>2</sup>	14.6827
Warm side air temperature, $\theta_{ei}$	°C	23.15
Cold side air temperature, $\theta_{ec}$	°C	-1.65
Surface temperature of the warm side, $\tau_{si}$	°C	19.687
Surface temperature of the cold side, $\tau_{se}$	°C	0.366
Temperature difference between surfaces, $\Delta \tau_s$	°C	19.321
Thermal resistance of insulation system, $R$	m <sup>2</sup> ·K/W	1.316
Thermal resistance of product, $R_{core}$	m <sup>2</sup> ·K/W	0.701
Uncertainty of the measurement, $\Delta R$	m <sup>2</sup> ·K/W	± 0.0426

Tested by: A. Burlingis



Date: 2023-11-21

Validity – the named data and results refer exclusively to the tested and described specimens.  
Notes on publication – no part of this document may be photocopied, reproduced or translated to another language without the prior written consent of the Building Physics Laboratory.

**Annex 2. Parameters of Guarded Hot Box measurement.**

**Table 1. Insulation system's specimen measured at 20°C/0°C temperature regime**

Guarded Hot Box measurement. Parameters of insulation system's specimen:							
Specimen's area A, m <sup>2</sup>		1.831		Actual mean thickness of specimen, mm		≈ 80	
Position of a specimen		vertical		Length of specimen perimeter L, m		5.44	
				Linear thermal transmittance of perimeter zone Ψ <sub>L</sub> , W/(m·K)		-0.006615	
Measurement data:							
Insulation system with product:							Result:
Sample No.	Temperature regime, °C	Hot side surface temperature τ <sub>h</sub> , °C	Cold side surface temperature τ <sub>c</sub> , °C	Temperature difference Δτ = (τ <sub>h</sub> - τ <sub>c</sub> ), °C	Measured heat flow density q, W/m <sup>2</sup>	Corrected heat flow density q <sub>e</sub> , W/m <sup>2</sup>	R-value of insulation system, m <sup>2</sup> ·K/W
217-3/23	20 / 0	19,6865	0,3660	19,3205	14,3033	14,6827	1,316±0,0426

**Annex 3. Specimen product and air gaps thermal properties**

**Table 2. Results of insulation product R-core value of direct measurement**

Product	Thickness, d mm	Hot side temperature τ <sub>h</sub> , °C	Cold side temperature τ <sub>c</sub> , °C	Temperature difference Δτ, °C	Heat flow density q <sub>c</sub> , W/m <sup>2</sup>	Product's core R <sub>c,m,pr</sub> value, m <sup>2</sup> ·K/W
217-3/23	≈20	15,4940	5,1953	10,2988	14,6827	0,701±0,0278

**Table 3. Insulation specimen air gaps values of direct measurement according to LST EN ISO 22097:2023**

Air gap number	Thickness d, mm	Measured temperature differences of surfaces, Δτ, °C	Air gap R value, m <sup>2</sup> ·K/W
Air gap #1	30	4.193	0.2855
Air gap #2	30	4.829	0.3289

**R-core thermal resistance value calculation according to LST EN ISO 22097:2023:**

$$R_{c,pr} = 1.316 - 0.2855 - 0.3289 = 0.701 \text{ (m}^2\cdot\text{K)/W}$$

Validity – the named data and results refer exclusively to the tested and described specimens.  
Notes on publication – no part of this document may be photocopied, reproduced or translated to another language without the prior written consent of the Building Physics Laboratory.

**Annex 4. Perimeter zone's linear thermal transmittance value of the specimen**

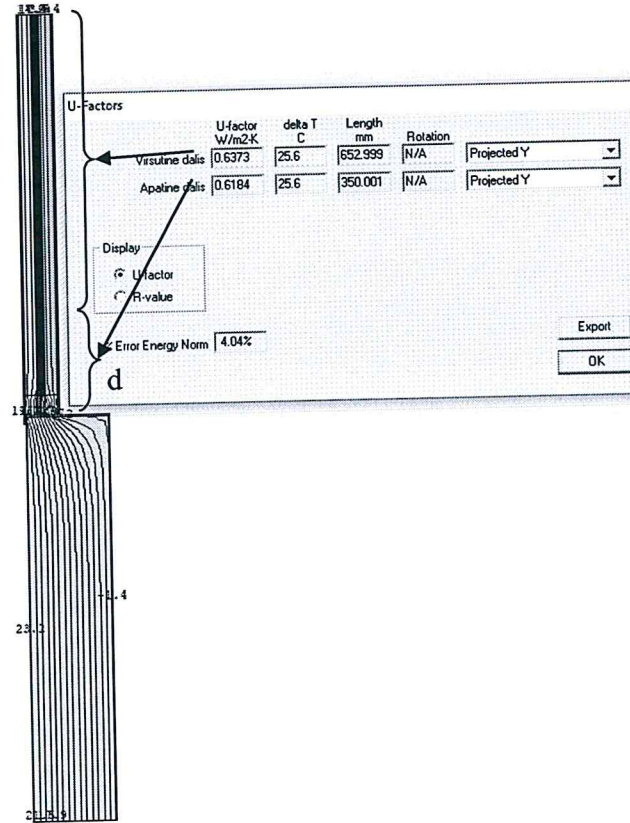

Perimeter zone's  $U$ -value:  $0.6184 \text{ W}/(\text{m}^2 \cdot \text{K})$ ; width "d" – 350 mm;

Central area  $U$ -value:  $0.6373 \text{ W}/(\text{m}^2 \cdot \text{K})$ .

Perimeter's linear thermal transmittance:  $\psi = (0.6184 - 0.6373) \cdot 0.350 = -0.006615 \text{ W}/(\text{m} \cdot \text{K})$ .

The correction of measured heat flow density value due to perimeter zone is calculated according to equation:

$$q_c = \frac{Q_c}{A} = \frac{Q - \psi \cdot L \cdot \Delta t}{A} = \frac{q \cdot A - \psi \cdot L \cdot \Delta t}{A} = q - \psi \cdot \left( \frac{L \cdot \Delta t}{A} \right);$$

here:

$A$  – area of a specimen,  $\text{m}^2$ ;

$Q$  – measured mean heat flow through a specimen,  $\text{W}$ ;

$q$  – measured mean heat flow density through a specimen,  $\text{W}/\text{m}^2$ ;

$Q_c$  – corrected mean heat flow through a central area of specimen,  $\text{W}$ ;

$q_c$  – corrected mean heat flow density through a central area of specimen,  $\text{W}/\text{m}^2$ ;

$L$  – perimeter length of a specimen,  $\text{m}$ ;

$\Delta t$  – ambient temperature difference across a specimen,  $\text{K}$ ;

$\psi$  – perimeter's linear thermal transmittance of a specimen,  $\text{W}/(\text{m} \cdot \text{K})$ .

Corrected R-value:  $R_c = \frac{\Delta \tau}{q_c}$ ;

$\Delta \tau$  – temperature difference across a specimen,  $\text{K}$ .

Validity – the named data and results refer exclusively to the tested and described specimens.  
Notes on publication – no part of this document may be photocopied, reproduced or translated to another language without the prior written consent of the Building Physics Laboratory.

Annex 5. Specimen design data

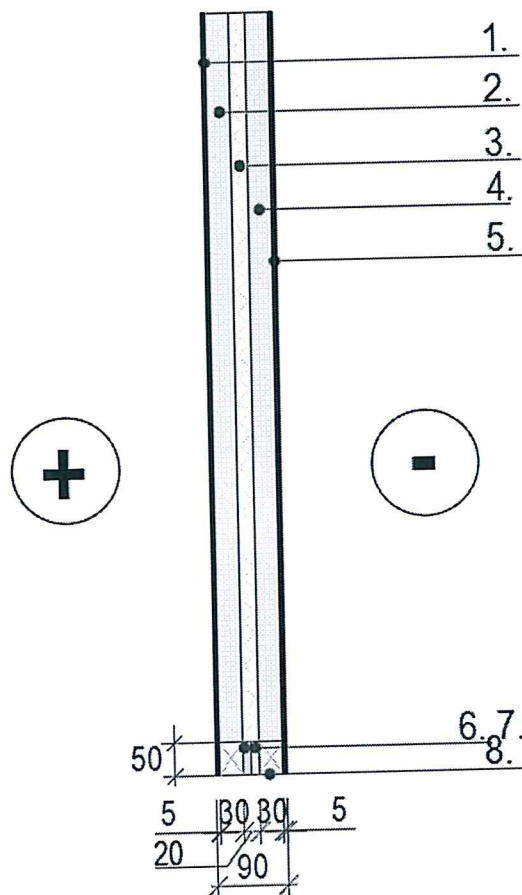

1.	PVC 5 mm
2.	Air gap 30 mm (#1)
3.	<b>BOLTHERM 820</b>
4.	Air gap 30 mm (#2)
5.	PVC 5 mm
6.	Plywood
7.	EPS (polystyrene)
8.	XPS (polystyrene)

Validity – the named data and results refer exclusively to the tested and described specimens.  
Notes on publication – no part of this document may be photocopied, reproduced or translated to another language without the prior written consent of the Building Physics Laboratory.

Annex 6. Scheme of climate chamber „Hot box“

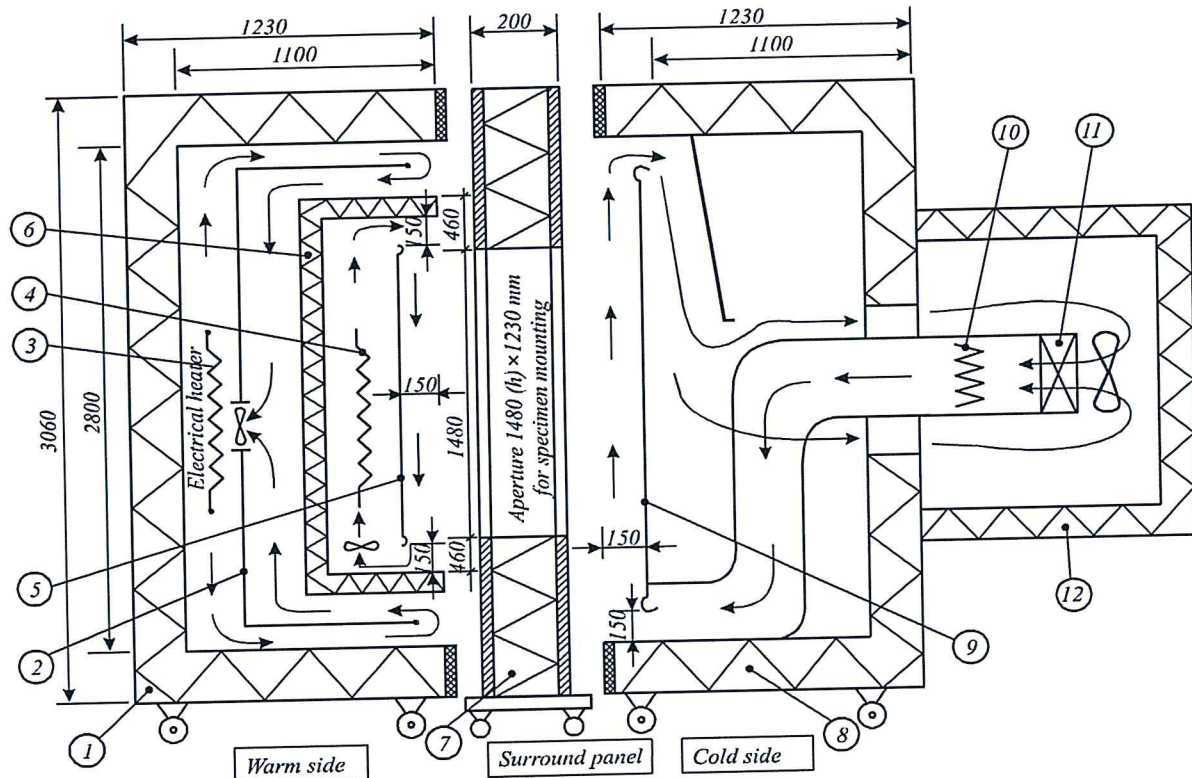

1. Warm side guard box:
  - internal dimensions 2800 × 2800 × 1100 mm;
  - wall thickness 130 mm, total thermal resistance about 3 m<sup>2</sup>·K/W.
2. Guard air flows deflecting screen.
3. Electrical heater, power 660 W, controlled according to a set point temperature in metering box (6).
4. Electrical heater of metering box, power control from 13W to 660 W.
5. Warm side baffle (of metering box) with surface and air temperature sensors.
6. Metering box – internal dimensions 2400 × 2400 × 360 mm.
7. Surround panel: 200 mm thick, core material EPS polystyrene (faced with 3 mm thick cellular PVC plastic sheet on either side), thermal resistance about 6 m<sup>2</sup>·K/W, 1484 x 1234 mm aperture for specimen mounting.
8. Cold side box:
  - internal dimensions 2800 × 2800 × 1100 mm;
  - wall thickness 130 mm, total thermal resistance about 3 m<sup>2</sup>·K/W.
9. Cold side baffle with surface and air temperature sensors.
10. Cold side box controlled
11. Cold side controlled cooling air unit, max. cooling power up to 3 kW.
12. Cold side air cooling box with 5 speed motor fan. electrical heater, max. power 2 kW.

Validity – the named data and results refer exclusively to the tested and described specimens.  
Notes on publication – no part of this document may be photocopied, reproduced or translated to another language without the prior written consent of the Building Physics Laboratory.